

All Rights Reserved

Materials and specifications are subject to change without notice.
Featured machines in photos may include additional equipment. See your XCMG dealer for available options.



Hydraulic Excavator
XE150E



XCMG European Sales & Services GmbH

Add: Europark Fichtenhain B 4, 47807 Krefeld, Deutschland

Tel: +49 (0) 2151 8209 351
Fax: +49 (0) 21 51-82 09-499
E-mail: Europe@xcmg.com

www.xcmg.com

XUZHOU CONSTRUCTION MACHINERY GROUP IMP. & EXP. CO., LTD

Add:NO.1, Tuolanshan Road, Xuzhou Economic Developing Zone,
Jiangsu,China 221004

Tel: +86 (0) 516 8773 9228
Fax: +86 (0) 516 8773 9230
E-mail: Europe@xcmg.com

Rated Power: 90 kW
Operating Weight: 15510 kg
Standard. Bucket Capacity: 0.61 m³





INTRODUCTION OF XCMG

Founded in 1943, XCMG is a multinational corporation with the most comprehensive range of competitive, influential products in the construction machinery industry. Our business covers eight key areas: construction machinery, heavy trucks, mining machinery, sanitation machinery, machinery components, construction, finance, and the ICT industry.

XCMG has established a global R&D network with a total of six centers in China, the US, Germany, Brazil and India, with China national technology center at its core. In addition to a number of manufacturing bases in China, the US, Germany, the Netherlands, Poland, Austria, Brazil, India, and Uzbekistan, we possess two complete machine brands (XCMG, Schwing), and several component brands including FT, AMCA. It is the strength of this global R&D network and manufacturing operations that has made XCMG the industry leading global construction equipment manufacturer that it is today.

For more than 30 years, XCMG has been sowing the seeds of overseas development as the No. 1 exporter in China's construction machinery industry. Today, we have 42 branches and offices, 315 distributors, 526 contractors in 188 countries and regions worldwide and are still growing rapidly.

XCMG IN EUROPE

Since its foundation in 2012, XCMG is gradually establishing a complete network including: R&D department, local distribution, supply chain management and an integrated customer services and training centre. Nowadays, with 4 branches, XCMG has 178 multinational employees in Europe, of which more than 50% are R&D engineers:

ERC: XCMG European Research Center GmbH

EPC: XCMG European Purchasing Center GmbH

ESS: XCMG European Sales and Services GmbH

Our local professional R&D team and cutting-edge innovation platform guarantee that our products are carefully crafted to the smallest detail according to the diverse needs of European customers.



XCMG XE150E builds on its reputation from the previous series based on the quality, reliability and durability. The enhancements deliver the best in class fuel efficiency while not compromising on power – reducing emissions and consumption, while increasing productivity.

If you are looking to get your work done with a durable brand you can trust – and be backed by unmatched support – look no further than our XE150E. It simply makes business sense – as well as an efficient & comfortable work environment.



► **RELIABILITY:**

Even in the harshest conditions, XCMG has made its aim to build long lifetime products. XCMG has already a long relationship with the best component suppliers in the world. Cummins engines, Kawasaki KPM hydraulic pumps, main control valve and swing motor, High quality travel motors guarantee you the best performance. Oversized cylinders in combination with long-life reinforced pins, polymer shims & bushings ensure best performance with unchanged durability.

► **PRODUCTIVITY AND EFFICIENCY:**

Strong and unmatched bucket and arm digging forces give XE150E the opportunity to fulfil the most challenging tasks on your jobsite with excellent productivity and efficiency.

► **SAFETY SOLUTIONS:**

Rear camera and large side mirrors, powerful LED lighting, anti-slip steps and platforms. Guard rails for accessing safely the upper structure. The ROPS (Roll Over Protective Structure) & OPG (Operator Protective Guard) cabin ensures the operator safety.

► **VERSATILITY:**

Different boom, arm sizes and other configurations (super long reach included) are available to efficiently carry out any task your business requires.

► **EASY-TO-USE ATTACHMENTS:**

Programmable auxiliary lines AUX1 (single and dual way) & AUX2 are provided to support your hydraulic attachments like, grabs, shear, hammer and many more.

► **COMFORTABILITY:**

To ensure operator comfort we offer a spacious cab with low noise & vibration levels and excellent all-round visibility. Fully adjustable heated air suspension seat, air conditioning with climate control as standard.

► **CONTROLLABILITY:**

7 work & 3 power modes, proportional control, user-friendly 8" TFT LCD colour monitor.

► **STRONG POWER:**

The Cummins QSB4.5 stage IV/Tier 4 Final engine is exceptionally powerful - with high torque at low revs. What makes that maximum flow already can be available at low rpm and a fuel-efficient engine regime can be delivered.

► **ADVANCED FILTRATION:**

Easy accessible high efficient filters & cleaners that remove all contaminations on your jobsite and protect your investment in the best possible way.

► **SIMPLE AND EASY MAINTENANCE:**

Easy access to all compartments. Maintenance data & signs are directly available from monitor.

► **UNDERCARRIAGE DURABILITY:**

The CAE designed X-shape undercarriage enables even weight distribution, increases stability and durability and prevents damage from rock and debris.



Excellent performance and fuel economy

► Power without compromise

The XE150E makes handling your task efficient and comfortable. The optimized Kawasaki-KPM hydraulic system makes sure that all that engine power is put into use in the best possible way by delivering accurate maximum pump in a smooth way. All that power has reliably increased the digging power, lifting capacities and traction force. Greater fuel efficiency means you can keep costs down and reduce environmental impacts.

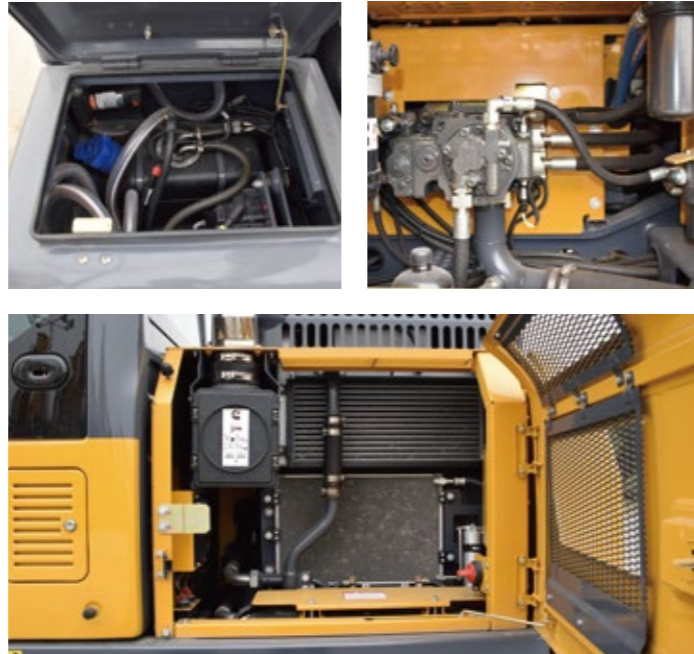
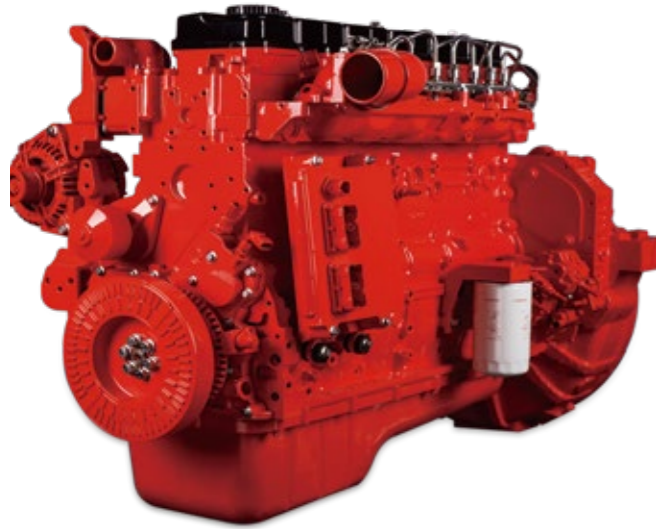

POWER MATCH TECHNOLOGY

The XE150E is equipped with a Cummins QSB4.5 engine. Famous for excellent fuel efficiency, reliability and long service life, it combines exceptional power output and high torque at low revs. The engine is fitted with high-pressure common-rail fuel system, combined with cooled exhaust gas recirculation (EGR) and Cummins VGT™ turbocharger, which increases the density of the air, enabling the engine to produce more power. Selective Catalytic Reduction (SCR) technology - combined with a Diesel Oxidation Catalyst (DOC) - ensures compliance with Stage IV regulations. As there is no need for a particulate filter, there is no need for regeneration. If the engine is the heart of the excavator, the XICS (XCMG Intelligent Control System) is its brain - providing a perfectly synchronized communication link between the engine's ECU (Electronic Control Unit) and the hydraulic system. A CAN (Controller Area Network) system enables a constant flow of information between engine and hydraulic system, so that power is delivered exactly as needed.

FUEL ECONOMY TECHNOLOGY

- Choice between 3 power modes and 7 working modes guarantees optimum performance in all conditions.
- Electronic control of fuel consumption optimizes efficiency.
- Auto-idle function can easily be ongoing after the machine has been idling for a specified time, to reduce unnecessary fuel consumption and exhaust emissions, and to lower operating costs.
- For optimum cooling, fan speed is controlled by a viscous clutch, resulting in lower fan noise & better fuel efficiency

Easy hydraulic maintenance:

- 2000/4000 hours of hydraulic oil replacement (depending to hydraulic oil model)
- Replace hydraulic oil return filter after 500 hours
- Replacement of hydraulic oil suction filter element in 2000 hours

Less engine service:

- 500 hours engine diesel filter replacement
- 500 hours engine oil and filter replacement
- The long service interval guarantees limited down-time.





First Choice for Comfort

The XE150E is designed to provide you with the best possible working conditions. The spacious cab allows the operator to create a working environment for increased productivity. The pressurized cab is ISO-certified for your safety. It offers a fully adjustable comfortable air-suspension heated seat, several storage compartments for your lunchbox and a clear all-round view of your jobsite. Reduced noise and vibration levels with automatic air-conditioning/climate-control will make your workday easy and comfortable.



Ergonomic operator environment

XCMG XE150E is powered by industry-leading engine that saves on fuel and meets the Stage IV/Tier 4 F emission regulations.

The variable speed cooling fan with viscous clutch makes sure that the fan is only engaged when it's needed. It reduces noise, fuel consumption and wear on the engine when compared to the classic fixed fan cooling. There is also a big advantage for operator to communicate on jobsite.

An air-suspension heated seat has been made standard.

By reducing noise, cab vibration and improve operator comfort we put the operator first!

Advanced Control technology

Ergonomic, advanced & simple-to-operate - Kawasaki's proportional joystick delivers ultra-precise & smooth control over all movements. The orientation of the roller and buttons are adjustable.

Air conditioning with automatic climate control

A choice from 5 different working modes to regulate airflow adjusts the systems air temperature & fan speed to maintain the optimal desired temperature. Recirculated air function is also available.

MP3/USB radio as standard and Bluetooth radio as option

Standard MP3/USB FM radio. Optional we now also offer the radio with bluetooth function.

Storage space

The new cab has 7 storage compartments - including hot/cool box, storage box for magazine/papers, and a cup holder.

Cab suspension

The cab's improved new suspension system dampens vibrations and smoothens out the roughest applications you are working at.

Quick coupler control

A standard quick coupler hydraulic system with pipelines are to exchange your attachment easily from the operator's seat. It facilitates the most common systems.

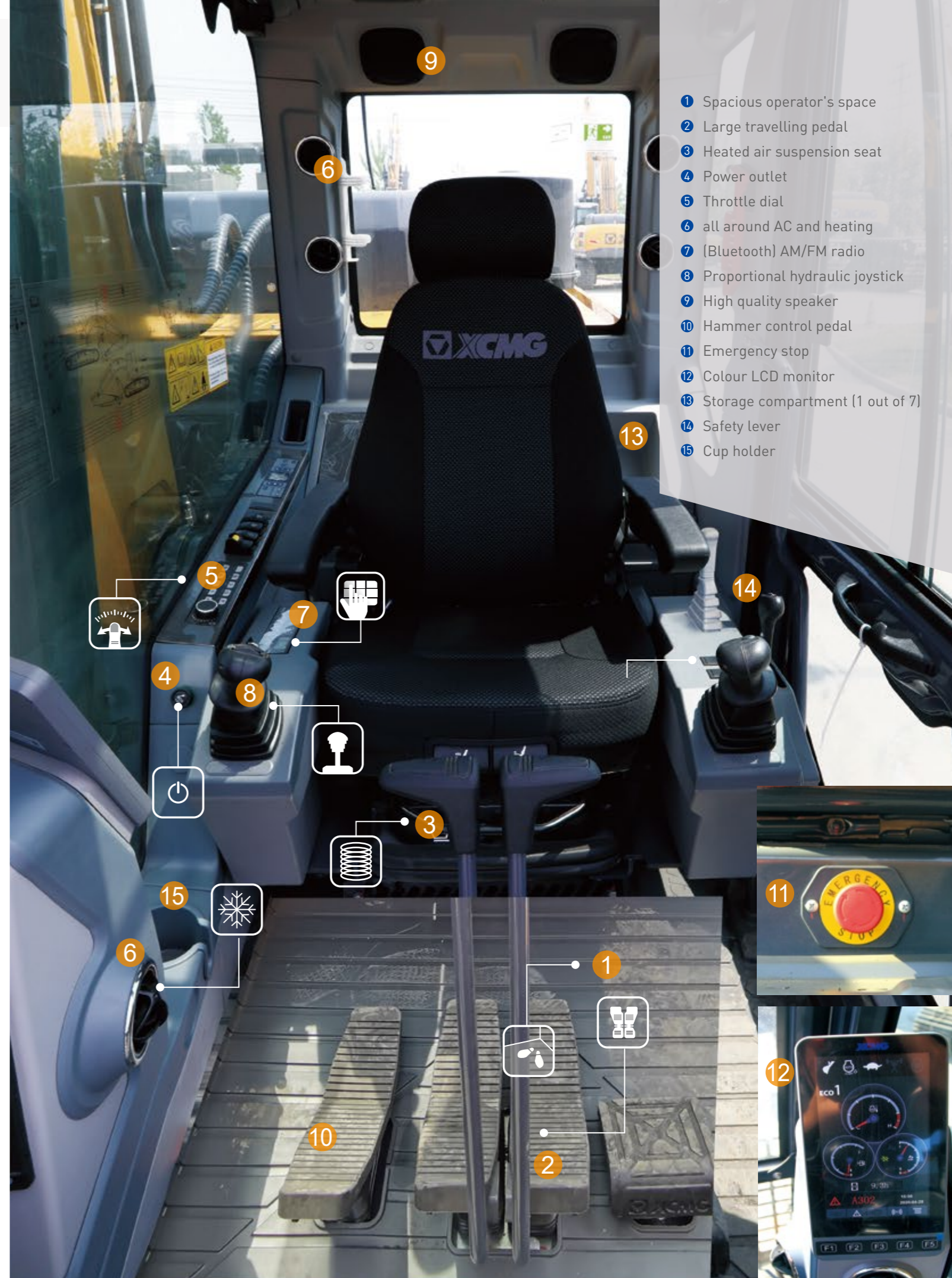

- 1 Spacious operator's space
- 2 Large travelling pedal
- 3 Heated air suspension seat
- 4 Power outlet
- 5 Throttle dial
- 6 all around AC and heating
- 7 (Bluetooth) AM/FM radio
- 8 Proportional hydraulic joystick
- 9 High quality speaker
- 10 Hammer control pedal
- 11 Emergency stop
- 12 Colour LCD monitor
- 13 Storage compartment (1 out of 7)
- 14 Safety lever
- 15 Cup holder

Machine interfaces

All machine interfaces – including joysticks, keypad, panel and larger LCD monitor – are ergonomically designed for optimum control and efficiency, resulting in increased productivity and workplace wellbeing. The switches have been simplified and climate control is now integrated into the keypad for easy adjustments.

- The new multi-function 8" TFT LCD monitor displays a comprehensive range of useful technical information, allowing you to check the machine's status and settings at a glance.
- Highly sensitive & low-effort joysticks and clear convenient controls enable you to work smooth & safely with minimum effort for increased comfort & efficiency.
- The newly adjustable proportional auxiliary functions mean precise and smooth control of your attachments.

Intelligent Monitor

The upgraded 8" TFT monitor features a day and night display and offers the user full access to the machine settings and maintenance data. Any abnormality is clearly displayed on the screen, allowing you to work safely and confidently with an accurate overview of all conditions.

All important data can be directly seen from the main screen.

- | | |
|------------------------|------------------------------------|
| 1. Work mode | 2. Auto idle |
| 3. Travel speed (H/L) | 4. Power boost |
| 5. Pre-heat indication | 6. Quick coupler operation warning |
| 7. Coolant temperature | 8. AdBlue level |
| 9. Hour meter | 10. Time and date |
| 11. Menu button | 12. Mute button |
| 13. Engine fault | 14. Fault information query |
| 15. Fault code | 16. Fuel level |

Dynamic power management

- Activating the power boost control system increases digging force by 8.8%
- Auto-idling starts 4 seconds after all controls are returned to neutral position and will decrease fuel consumption.

7 Work modes & 3 Power modes

Deliver the needed power according to your specific application while minimizing fuel consumption:

- N: Normal excavation mode,
- T: Plateau mode,
- ATT1: Breaker mode,
- ATT2: Shear mode,
- ATT3: Thumb plier mode,
- ATT4/5: Auxiliary modes.
- H: Heavy-duty mode,
- S: Standard mode,
- Eco: Economy mode



Air cleaner



Pre-cleaner

Pre-cleaner: air filter life & engine efficiency are directly related to the amount of debris ingested through the engine's air intake. Therefore, pre-cleaner (as standard) is the first stage of an air intake system that prevents the majority of heavier-than-air particles from entering.

► Designed for long-term robustness and safety

XCMG has developed one of the most rigorous strength & reliability testing procedures, XCMG E-series feature durability in the most extreme conditions and is therefore also one of the most popular brands in its home market. We continually manufacture the most durable machines to reduce costs of ownership. The robust upper frame, undercarriage structure and the front attachments show the real value in tough working environments and promise higher productivity.

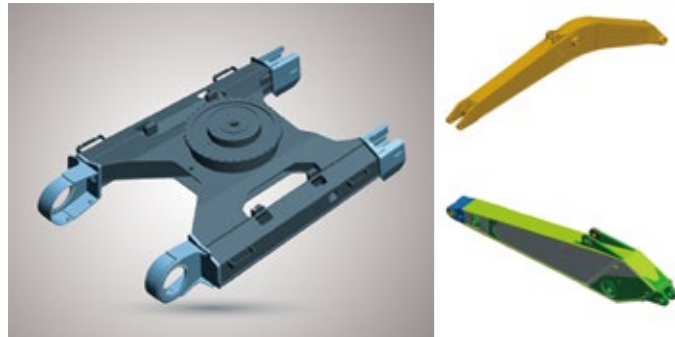

Reinforced durability of X-chassis

The X-shaped undercarriage has higher durability than demanded on the site, as proven through numerous tests including road tests and virtual simulation.

Undercarriage durability

- The chain is composed of sealed, self-lubricating links for long-term dependability
- The track spring and idler are developed for long-lasting performance and easy maintenance
- Cast steel heavy-duty sprockets guarantee the highest resistance
- Track rollers lubricated for long-term durability

Strengthened boom & arm

FEA has been used to calculate the best load distribution throughout the boom structure. To better protect the base of the arm, reinforced bars have been added and the arm center and end structure have been strengthened.

Hi-grade (High-pressure) Hoses

The E-series uses high-pressure hoses with improved heat and pressure resistance, greatly increasing the durability of the equipment.

Reinforced Pin, Bush and Polymer Shim

The new series improves lubricity of connecting parts between the equipment and attachments. Gaps with attachments are minimized by wear-resistant long-life pins, bushes and polymer shims, supporting the highest performance with invariable durability.

► Excellent serviceability

Our machines are designed for simple routine maintenance, while skilled XCMG technicians are available to provide extra support if you need. To get the most out of your machine, choose the package you need from a broad range of service agreements. Uptime, productivity and residual value are all maximized, making XE150E an economical and rewarding choice.



Simple and easy Maintenance

- Large guard rail is installed along with anti-slip steps and plates, for safer and easier access to the upper structure
- Cab's air-conditioning filter is lockable and placed on the cab's side for easy access
- Battery cut-off switch to easily disconnect the battery or jobsite required safety measures.
- Shut-off valves on the pre-filter piping line and fuel tank drain piping make servicing easier and prevent pollution from leakage
- Engine parts can be easily reached via the top and side panels
- For extra accessibility and servicing convenience, all filters (engine oil filter, fuel pre-filter, fuel filter and pilot filter) are located in the pump compartment.

Pre-start monitoring system

The XE150E has a pre-start monitoring system that shows you coolant temperature, hydraulic oil temperature, engine oil pressure, fuel levels and AdBlue® level. It will also indicate fluid and filter intervals to keep the machine in top performing condition.

Proactive Maintenance Solutions

- Extended warranty: extended warranty covering parts, travel and service available
- Routine maintenance: your dealer will support you with routine service at regular intervals
- Genuine parts: manufactured and tested to ensure long lifetime of your machine.

SCR Tank & easy Diesel filling

Connected to the ECU, sensors in tank detects low level of AdBlue® & potential system malfunctions.

Fuel filler pump, an on-board pump system, lets you fill your fuel tank quickly from an external source (like a fuel drum) – the system stops automatically when the fuel tank is full or the fuel source is empty.

Centralized lubrication greasing points

To make maintenance easier.

■ Engine

Designed to deliver superior performance and fuel efficiency, the Cummins Stage IV diesel engine fully meets the emissions regulations. To optimize machine performance, the engine uses high-pressure fuel injectors, VGT™ turbocharger inter-cooler and electronic engine controls. 4-Cycle Water-Cooled, turbocharged, Exhaust Gas Recirculation (EGR) & Selective Catalytic Reduction (SCR) without Diesel Particulate Filter (DPF).

XE150E	
Model	Cummins QSB4.5
No. of cylinders	4
Rated power at 2100 rpm (SAE J1995)	90 kW (121 hp) at 2200RPM
(SAE J1349)	—
(ISO 9249)	—
Max. torque at 1500 rpm	48.0 kgf.m (470 Nm)
Idle (low - high)	700 - 2100 rpm
Piston displacement	275 in ³
Bore × stroke	107mm × 124 mm
Starter	24 V × 4.8 kW
Batteries - Alternator	2 × 12 V, 90 Ah - 24 V, 70 A
Air filter	"Donaldson the latest PSD air filter and pre-filtered dust separator"

■ Undercarriage

Extremely robust construction throughout - made of high-quality, durable materials, with all welded structures designed to limit stresses.

- Lifetime lubricated track rollers idlers and sprockets fitted with floating seals
- Track shoes made of induction-hardened alloy with triple grouser
- Heat-treated connecting pins
- Hydraulic track adjuster with shock-absorbing tension mechanism

• Number of rollers and track shoes per side

XE150E	
Upper rollers (standard shoe)	1
Lower rollers	7
Number of links & shoes per side	45
Overall track length	3658

■ Weight

	Shoe width (mm)		Operating weight (t)	Ground pressure [kgf/cm ²]
	500(Std)	600		
Triple grouser	600	700	15510	47
	700	800	15720	40
	700	800	15940	35
			16150	31

■ Component weights

Item	Unit	XE150E	Remarks
Upper structure without front	kg	8368	With counterweight
Lower structure assembly	kg	5268	600mm shoe
Front assembly	kg	2083	Without cylinder
Counterweight	kg	2960	Standard counterweight:
Boom	mm / kg	4600/896	including bushing
Arm	mm / kg	2520/457 3010/539	including bushing

■ Hydraulic system

The XICS (XCMG Intelligent Control System) is the brain of the excavator - minimizing fuel consumption and enabling the efficiency of the hydraulic system to be optimized for all working conditions. To harmonize the operation of the engine and the hydraulics, the XICS is connected to the engine's electronic control unit (ECU) via a data transfer link.

- The hydraulic system enables independent or combined operations - 2 travel speeds offer either increased torque or high speed
- Cross-sensing pump system for fuel savings - Auto-deceleration system
- 7 work modes, 3 power modes - Flow and pressure control of auxiliary hydraulic circuits from control panel
- Computer-aided pump flow control

• Pump flow and system pressure

XE150E	
Main pumps, type:	"2 × variable displacement tandem axial piston pumps"
Maximum flow at 1750 rpm	2 × 114 l/min
Pilot pump, type:	Gear pump
Maximum flow at 1750 rpm	17.5 l/min
Relief valve settings:	
Pressure up	350/380 kg/cm ²
Travel	350 kg/cm ²
Swing	255 kg/cm ²
Pilot	40 kg/cm ²

■ Hydraulic cylinders

High-strength steel piston rods and cylinder bodies. Shock-absorbing mechanism fitted in all cylinders for shock-free operation and extended piston life.

Cylinders	Quantity	Bore × rod diameter × stroke (mm)
boom	2	105 × 70 × 941
Arm	1	115 × 80 × 1120
Bucket	1	100 × 70 × 875

■ Swing mechanism

The swing mechanism uses an axial piston motor, driving a 2-stage planetary reduction gear bathed in oil for maximum torque.

- Swing bearing: single-row, shear type ball bearing with induction hardened internal gear
- Internal gear and pinion immersed in lubricant

• Swing speed & torque

XE150E	
Maximum swing speed	11.7 rpm
Maximum swing torque	34 kN.m

■ Drive

Each track is driven by an independent, high-torque axial piston motor through a planetary reduction gearbox. Two levers / foot pedals guarantee smooth travel with counter-rotation on demand.

The track frame protects the travel motor, brake and planetary gears. The multi-disc track brakes are spring-applied and hydraulic released.

• Speed & traction

XE150E	
Travel speed (low - high)	3.2- 5.3 km/h
Maximum traction	13.3 ton
Maximum gradeability	35° / 70%

■ Fluid capacities

XE150E	
Fuel tank	260 L
Cooling system (radiator)	16 L
Urea (def) tank	14.8 L
Hydraulic oil tank	105 L
Engine oil	11 L
Swing drive	1.8
Travel device	2×2.1

■ Cab

The air-conditioning and heating systems are integrated for optimal climate control. An automatically-controlled fan supplies the pressurized and filtered cab air, which is distributed throughout the cab from multiple vents. The heated air suspension, adjustable operator's seat includes a seat belt. The operator can adjust the ergonomic seat and joystick console separately according to his preferences.

Note - Declared single-number noise emission values are the sum of measured values and the associated uncertainty, and they represent upper boundaries of the range of values which is likely to occur in measurements.

• Noise emission

XE150E	
Noise Lever LpA (ISO 6396)	71 dB(A)
Noise Lever LwA (ISO 6395)	101 dB(A)

■ Buckets

Bucket Type	Capacity (m ³) SAE	Width (mm)		Weight (kg)	boom 4.6m		
		With side cutters	W/O side cutters		arm 2.52m	arm 2.1m	arm 3.0m
					Shoe 500mm	Shoe 500mm	Shoe 500mm
GP	0.32	600	600	376	A	A	A
	0.4	880	822	430	A	A	A
	0.6	1096.9	1040.2	501	A	A	B
	0.7	1239	1182.2	539	B	A	C
HD	0.52	1012	1012	497	A	A	A
	0.55	1040	1040	515	A	A	A
	0.6	1112.4	1112.4	528	A	A	B
	0.65	1160	1160	538	A	A	B
SD	0.7	1258.4	1258.4	569	B	A	C
	0.52	930	930	513	A	A	A

GP: General purpose; HD: Heavy duty; SD: Severe duty;

A: Suitable for materials with a density less than or equal to 2100 kg/m³;

B: Suitable for materials with a density less than or equal to 1800 kg/m³;

C: Suitable for materials with a density less than or equal to 1500 kg/m³;

Based on ISO 10567 and SAE J296, arm length without quick-coupler. For reference only.

Standard track width: 2490 mm · W/O Bucket

Unit: 1000 kg	A		1.5 m		3.0 m		4.5 m		6.0 m		Max. reach	
	B										A	
One-piece boom 4.60 m Arm 2.52 m Shoe 500 mm Counterweight 3.0 t	6.0 m				3.2*	3.2*			2.5*	2.5*	5.4	
	4.5 m				3.4*	3.4*	3.3*	2.5	2.4*	2.3	6.4	
	3.0 m			5.6*	5.6*	4.1*	3.8	3.5*	2.5	2.3*	2	6.9
	1.5 m			8.1*	6.4	5.0*	3.6	3.7	2.4	2.5*	1.9	7
	0.0 m			7.1*	6.1	5.5	3.4	3.6	2.3	2.8*	1.9	6.9
Counterweight 3.0 t	-1.5 m	4.9*	4.9*	8.6*	6	5.4	3.3	3.6	2.3	3.3	2.1	6.4
	-3.0 m	9.0*	9.0*	7.3*	6.1	5	3.4			3.8*	2.7	5.4

Unit: 1000 kg	A		1.5 m		3.0 m		4.5 m		6.0 m		Max. reach	
	B										A	
One-piece boom 4.60 m Arm 2.52 m Shoe 600 mm Counterweight 3.0 t	6.0 m				3.2*	3.2*			2.5*	2.5*	5.4	
	4.5 m				3.4*	3.4*	3.3*	2.5	2.4*	2.3	6.4	
	3.0 m			5.6*	5.6*	4.1*	3.8	3.5*	2.5	2.3*	2	6.9
	1.5 m			8.1*	6.4	5.0*	3.6	3.7	2.4	2.5*	1.9	7
	0.0 m			7.1*	6.1	5.5	3.4	3.6	2.3	2.8*	1.9	6.9
Counterweight 3.0 t	-1.5 m	4.9*	4.9*	8.6*	6	5.4	3.3	3.6	2.3	3.3	2.1	6.4
	-3.0 m	9.0*	9.0*	7.3*	6.1	5	3.4			3.8*	2.7	5.4

Unit: 1000 kg	A		1.5 m		3.0 m		4.5 m		6.0 m		Max. reach	
	B										A	
One-piece boom 4.60 m Arm 3.01 m Shoe 500 mm Counterweight 3.0 t	6.0 m				2.9*	2.9*			2.3*	2.3*	5.9	
	4.5 m				3.1*	3.1*	3.0*	2.3	2.2*	2.1*	6.8	
	3.0 m			5.2*	5.2*	3.8*	3.5	3.2*	2.3	2.1*	1.8	7.3
	1.5 m			7.5*	5.9	4.6*	3.3	3.4	2.2	2.3*	1.7	7.4
	0.0 m			6.6*	5.6	5.1	3.1	3.3	2.1	2.6	1.7	7.3
Counterweight 3.0 t	-1.5 m	4.5*	4.6*	7.9*	5.5	5.0	3.0	3.3	2.1	3.0	1.9	6.8
	-3.0 m	8.3*	8.3*	6.7*	5.6	4.6	3.1			3.5*	2.5	5.9

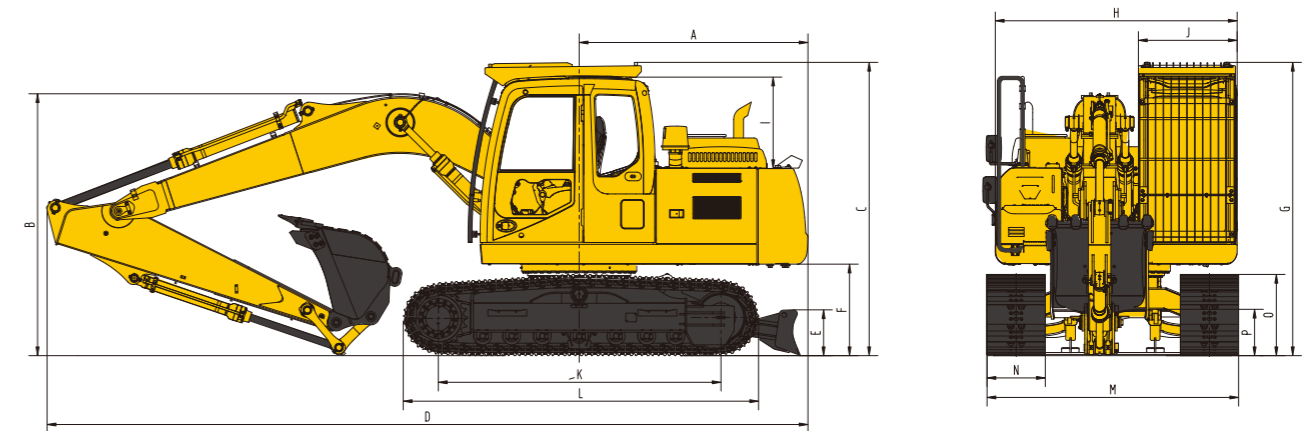

Dimensions

	XE150E	One-piece boom	
Boom length - mm		4600	
Arm length - mm		2520	3010
Bucket capacity - m ³		0.61	0.52
A Tail swing radius - mm	2355	2355	
B Shipping height (boom) - mm	2705	2781	
C Shipping height (Cab) - mm	3020	3020	
D Shipping length - mm	7833	7833	
E Dozer height - mm	472	472	
F Counterweight clearance - mm	942	942	
G Height over cab - mm	3020	3020	
H House width - mm	2490	2490	
I Cab height above house - mm	943	943	
J Cab width - mm	1010	1010	
K Tumbler distance - mm	2910	2910	
L Track length - mm	3658	3658	
M Undercarriage width - mm	2490	2490	
N Shoe width std. - mm	500	500	
O Track height - mm	836	836	
P Ground clearance - mm	477	477	

Digging forces (ISO)

	XE150E	One-piece boom	
Boom length - mm		4600	
Arm length - mm		2520	3010
Bucket capacity - m ³		0.61	0.52
BUCKET [Normal/Press. Up] - ton	99/106.9	99/106.9	
ARM [Normal/Press. Up] - ton	70.6/73.4	56.1/60.5	

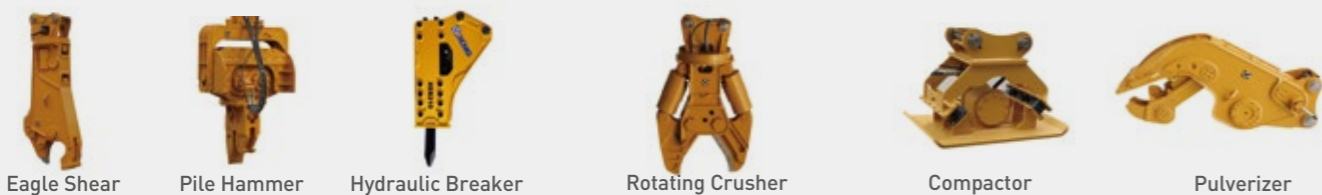

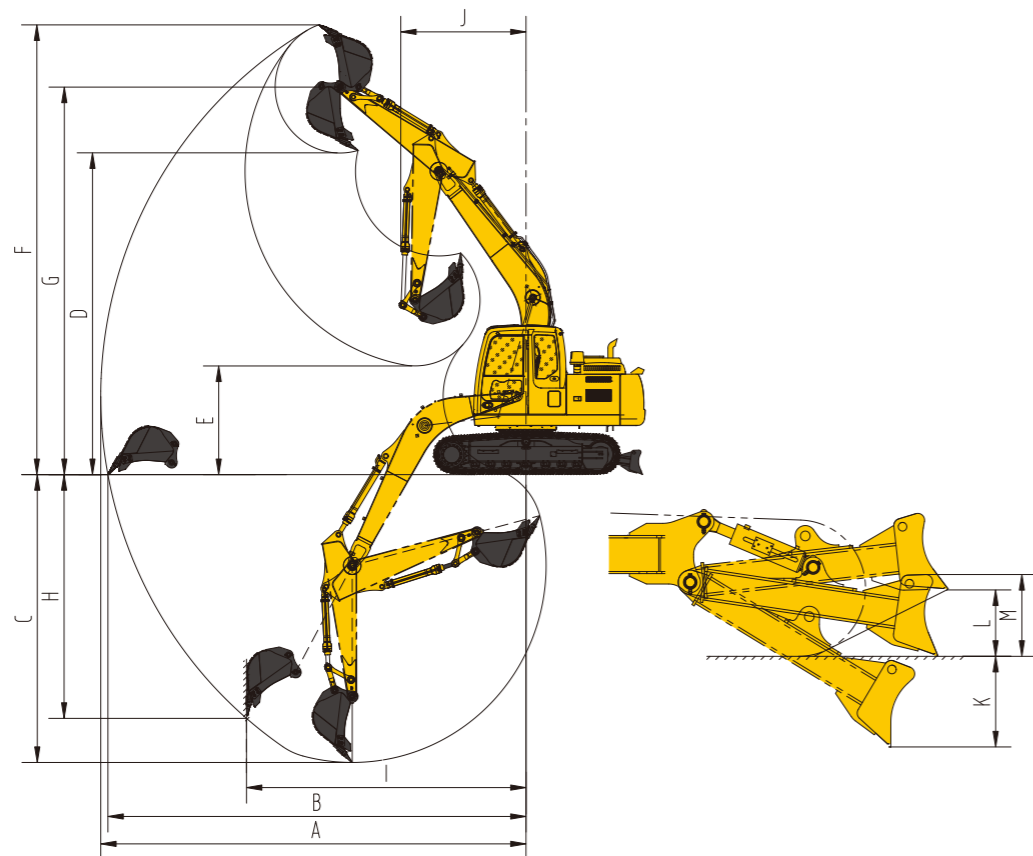

Working range

XE150E		One-piece boom	
Boom length - mm		4400	
Arm length - mm		2520	3010
Bucket capacity - m ³		0.61	0.52
A	Max. digging reach - mm	8304	8751
B	Max. digging reach (ground) - mm	8164	8619
C	Max. digging depth - mm	5535	6023
D	Max. loading height - mm Min.	6185	6430
E	loading height - mm	2088	1619
F	Max. digging height - mm	8649	8903
G	Max. bucket pin height - mm	7449	7551
H	Max. vertical wall depth - mm	4697	5265
I	Max. radius vertical - mm	5452	5452
J	Min. swing radius- mm	2445	2445
K	Maximum Blade depth - mm	523	523
L	Maximum Blade height - mm	383	383
M	Blade height - mm	472	472

Engine

AdBlue	●
Automatic preheating	●
Fuel-water separator with water level indication sensor	●
Fuel-water separator with heater [24V]	○
Axial seal air cleaner	●
Air prefilter	●
50 C high temperature ambient cooling assembly	●
Dust screen for radiator	●
Fuel marker	●
Oil-water quick release device	●
Fuel filling pump 50L/min	●
Fuel breather valve	●
Air filter service indicator	●
Auto-idle function	●

Hydraulic System

Auxiliary hydraulic valve	●
One & two way hydraulic line for hammer&thumb plier	●
Hydraulic quick coupler lines	●
Tilting and rotating lines	●
Hydraulic oil ISO VG 46	●
Hydraulic oil ISO VG 32	○
Hydraulic oil ISO VG 68	○
Right electric proportional joystick	●
Left electric proportional joystick	●
Spare valve plate	●
Gauge pressure monitoring	●

Cab & Interior

Pressurised cab	●
Air suspension seat with heater	●
Control box	●
Rain visor	●
Front windshield divided 70/30 ratio	●
Double laminated windshield and other toughened windows	●
Sliding fold-in front window	●
Bi-directional air outlet air conditioner with defroster [automatic type][pressurization function]	●
Colour LCD capable of displaying warning information,filter / liquid replacement information and working hours	●
Travel control pedal with detachable manual control lever	●
Double stereo speaker	●
Cup holder	●
Coat hook	●
Floor mat	●
Retractable seat belt [51 mm [2"] wide]	●
High and low travel speed switch	●
One-key boost mode	●
Reserve switch for working aids	●
Sunlight protection,roof	●
Top sunroof	●
Windshield wiper with intermittent feature	●
File packet	●
Hot and cool box	○
Rear window emergency exit	●
Hammer for emergency escape	●

Undercarriage

One rail clamps on the left and right of the track	●
2x45 Joint track, 2x7 bottom roller	●
2x1 top roller	●
Bottom frame traction ring	●
500 mm [20"] triple grouser track shoes	●
Protective device kit: undercarriage bottom sealing plate, travel motor sealing plate	○
600 mm [24"] triple grouser track shoes	○
700 mm [28"] triple grouser track shoes	○
800 mm [31"] triple grouser track shoes	○
Track rubber block	○

Working device

Boom 4.6m	●
Arm 2.52m	●
0.61m ³ Reinforced bucket	●
Arm 2.1m	○
Arm 3.01m	○
0.52m ³ Rock bucket	○
18 inches width ditching bucket	○

Electronic system

Battery [2x 750 CCA]	●
50A 24VDC generator	●
3.8 kW starter motor	●
24V Cigarette lighter	○
12V Cigarette lighter	●
5V USB interface	●
Emergency stop	●
Rear-view camera	●
360° full range image	○
AM-FM radio with digital display	●
Travel buzzer with switch	●
Beacon lamp	●
2 LED cab-mounted front lights	●
1 LED cab-mounted rear light	●
2 LED boom-mounted lights	●
12V power interface	○
Ceiling light	●

Counterweight

2.95 t counterweight	●
----------------------	---

Lubrication system

Centralized lubrication greasing points	●
---	---

Safety

Side impact beam	○
Driving door locks and cabin locks	●
Alarm horn	●
Quickcoupler switch with buzzer	●
Isolation plate between engine and oil pump chamber	●
Battery circuit breaker	●
Overheat alarm	●
Safety handrails and pedals	●
Anti-skid plate/ anti-skid paste	●
Hydraulic safety locking lever	●
Right and left rear-view mirrors	●
Counterweight rear-view mirrors	○
Safety valves for boom cylinders	●
Safety valve for arm cylinder	●
Roll over protective structure [ROPS]	○
Operator protective guard [OPG]	○
Safety net on the front lower windshield	●

Standard: ●
Optional: ○

Some of these options/equipment may not be available for certain markets. Please contact your local XCMG dealer for more information on availability or to customise your machine to suit your application requirements.



XCMG approved attachments



Genuine parts



Extension of warranty



Financial solutions



Maintenance contract



Telematics



Monitoring systems

Professional Integrated Complete Solutions

XCMG group has built a strong reputation based on the quality, reliability and durability of its construction machinery. What's more, XCMG has gradually established a service network to constantly provide its local integrated and highly efficient complete solutions for all customers..

Full Range of Services Ready for you

In order to respond to your needs as fast as possible, XCMG experts are on their way to your job site from one of our facilities near you. Full range of services are available in order to reduce your total cost of ownership and increase your revenue.



XCMG Global Spare parts System



Mobile cranes



Excavators



Aerial work platforms



Wheel loaders



Road machinery

